

ASSEMBLY MANUAL

**BEFORE MOUNTING, CONSULT
A CHIMNEY SWEEP**

1. Forge an opening in the chimney for a washout hole and a tee (figure no. 1) or for the washout hole alone. The chimney liner is designed to rest on a condenser bottom fixed on the washout hole element. Therefore, prepare a relevant support for the condenser bottom so that it remains stable and safe on its entire surface. The minimum height of the washout hole door is 30cm from the floor.

2. Measure the chimney wall thickness and adjust the box of the washout hole (dimension A) so that the washout hole door fits tight to the wall after the installation.

Note: The box inclines approx. 2° towards the chimney which prevents the condensate from dripping out of the washout hole. When fitting the washout hole door, adjust the inclination of the frontal box surface of the washout hole. When the box is too long, cut it appropriately with metal sheet shears.

3. Drill at least 4 openings, diameter from 4.0 to 4.2 mm, in the washout hole box and in the door frame. Mount the door by riveting it to the washout hole box (use rivets from acid-proof steel 4 mm).

4. Fit a tee or a pipe, and then a tee, in the washout hole.

5. Join the chimney components by inserting one component into the next muff. **All elements need to be mounted with the muff up. Incorrect mounting will result in the dripping of condensate.**

6. Transport the pipe elements, the roof passage and the chimney termination to the installation site (the installation is usually conducted from the roof level). Preassemble sections containing several pipes (according to the comments in items 4 and 5) and lower them down with the help of a rope (figure 2). Continue until the entire chimney is assembled and the first pipe is connected to the tee. To keep the entire structure tight, draw all connections (except for the last one) over the entire muff length. Insert the last element 85 mm deep into the muff.

7. Put the roof passage on the last pipe (before assembling it with other pipes).

8. After assembling the last pipe (with the roof passage) with the others, permanently fix the roof passage to the chimney with the use of screws and dowels, keeping a distance of at least 1 cm (e.g. by putting rubber blocks underneath) to ensure the ventilation of the ceramic chimney.

9. Install the chimney roof* and permanently connect it with the pipe by riveting.

***Note: do not use with coal fuels.**

10. Brickwork the washout hole and the tee. To avoid stresses, isolate the chimney liner from the masonry mortar with an insulation material (e.g. mineral wool) or special rings.

When brickworking the washout hole, pay particular attention to keeping an appropriate condensate draining from the condenser bottom. The draining tap of the condenser bottom must never be choked (closing the tap is forbidden. Due to condensate contamination, it is recommended to use condensate neutralizers offered by the manufacturer.

11. NOTE: Additionally protect segments of the adjustable knee used as an element of the flue connection after their initial adjustment with a sealant.

12. Where the ceramic chimney height over the roof exceeds 0.3 m (dimension L1 on figure 3), insulate the pipes of the chimney liner with the use of mineral wool or special insulation sleeves over the section of the chimney end to the level below the roof surface. Provide such insulation also when the chimney passes through „cold”, unheated rooms (e.g. an attic).

13. When assembling the chimney, follow the instructions contained in the „Technical conditions for the execution and selection of boiler stations” with regard to exhaust flue gas discharge systems.

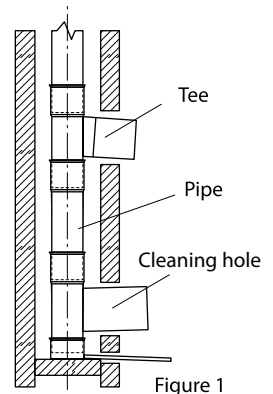

Figure 1

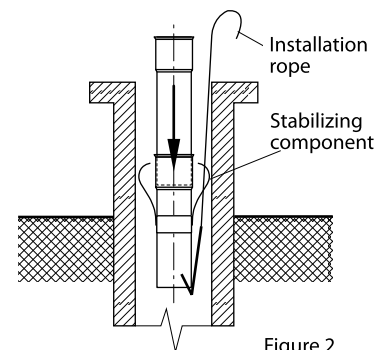

Figure 2

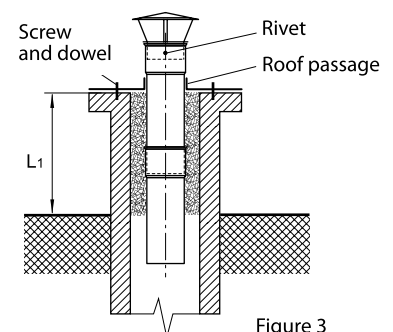

Figure 3