

INSULATED CHIMNEYS

TYPE SLIM EKO NEGATIVE PRESSURE

Example of marking elements manufactured according to the standard EN 1856-1

	EN 1856-1	T450	N1	W	V _m	L50050	G100
Standard number	↓						
Maximum working temperature		↓					
Pressure class (N: negative pressure, F: positive pressure)			↓				
Resistance to condensate (W: wet; D: dry)				↓			
Resistance to corrosion according to type and thickness of material					↓		
Material specification (50 - steel 1.4404)						↓	
Thickness of material (0.XX mm)							↓
Resistance to soot fire (G: yes; O: no), distance from flammable materials (100 mm)							↓



INSULATED CHIMNEYS

TYPE SLIM EKO NEGATIVE PRESSURE

SLIM EKO insulated chimneys are a new solution that summarizes over 20 years of Komin Flex's experience in the field of modern exhaust gas technology.

With their construction adapted for difficult working conditions, SLIM EKO chimneys are dedicated to meet the needs of 5 class solid fuel boilers. The main threats to the operation of chimneys connected to modern boilers include low exhaust gas temperatures, large amount of aggressive condensate, increased demand for chimney draft resulting from higher exhaust gas resistance through the boiler, as well as modulated boiler operation.

Therefore, a properly working chimney, resistant to harmful combustion products, well thermally insulated and equipped with all necessary attributes is an indispensable element for proper and long-term operation of a boiler fuelled with solid fuel of good quality. The SLIM EKO chimney has all these features and can thus be used as an external chimney, it is also recommended as new internal chimney duct due to the ease of assembly and materials used.

The elements of insulated chimneys type SLIM consist of:

- an internal chimney liner made from acid-proof steel type 1.4404/0,8mm
- a thermal insulation from special mineral wool, thickness 30 mm and density at least 100 kg/m³
- an external jacket made from acid-proof steel type 1.4301, polished surface.

The essence of the effectiveness of the metal insulated Slim EKO chimney are complete elements made of the best types of chromium steels (acid-resistant and stainless) with thicknesses adequate to difficult working conditions. The assembly of elements with a maximum length of 1m is not problematic, the assembly and cleaning elements, as well as supports allow for easy configuration of the chimney. Additional elements of endings, roof flashings, and covers are adapted to the line to make this system even more attractive.

Insulated chimneys type SLIM comply with the following European standards: EN 1443 and EN 1856-1,2. The production of insulated chimneys is covered by a system of factory production control, certificate No 1020-CPD-070038635 (TZUS Praga). KOMIN-FLEX has implemented and maintains a quality management system compliant with the requirements of the standard EN ISO 9001:2015 certified by TZUS Praga.

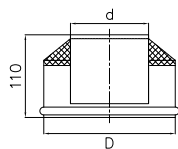

MOUTHPIECE SLIM EKO *in diameters 150, 180 i 200 mm the tip of the mouthpiece makes it possible to mount chimney covers

trade diam. d	130	150	160	180	200	225	250	300	350	400	450	500
trade diam. D	190	210	220	240	260	285	310	360	410	460	510	560

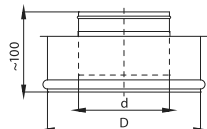

UPPER INSULATION ENDING

trade diam. d	130	150	160	180	200	225	250	300	350	400	450	500
trade diam. D	190	210	220	240	260	285	310	360	410	460	510	560

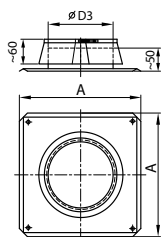

ROOF PASSAGE + OPD SLIM SLIM

trade diam. d	130	150	160	180	200	225	250	300	350	400	450	500						
D3	202	222	232	252	272	297	322	372	422	472	522	572						
A	333			400			450			500			550		600		650	

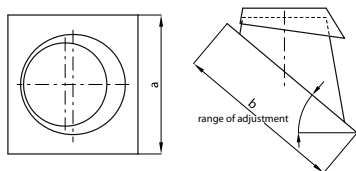
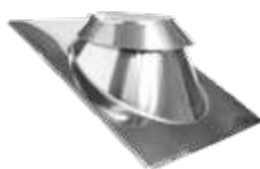

ADJUSTABLE ROOF PASSAGE + OPD

trade diam. d	130	150	160	180	200	225	250	300	350	400	450	500
trade diam. D	200	220	220	250	270	295	320	370	420	470	520	570
range of adjustment	base board dimension a x b											
5° + 30°	400 x 400			450 x 450						600 x 600		
above. 30° + 50°	400 x 450			450 x 550						600 x 750		

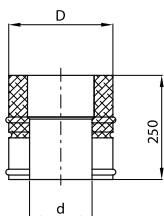

PIPE SLIM EKO 0,25 m

trade diam. d	130	150	160	180	200	225	250	300	350	400	450	500
trade diam. D	190	210	220	240	260	285	310	360	410	460	510	560

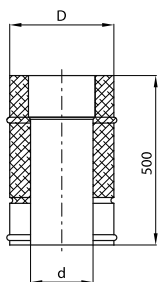

PIPE SLIM EKO 0,5 m

trade diam. d	130	150	160	180	200	225	250	300	350	400	450	500
trade diam. D	190	210	220	240	260	285	310	360	410	460	510	560

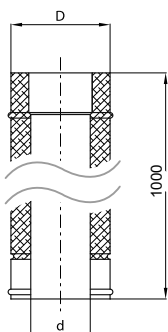

PIPE SLIM EKO 1 m

trade diam. d	130	150	160	180	200	225	250	300	350	400	450	500
trade diam. D	190	210	220	240	260	285	310	360	410	460	510	560

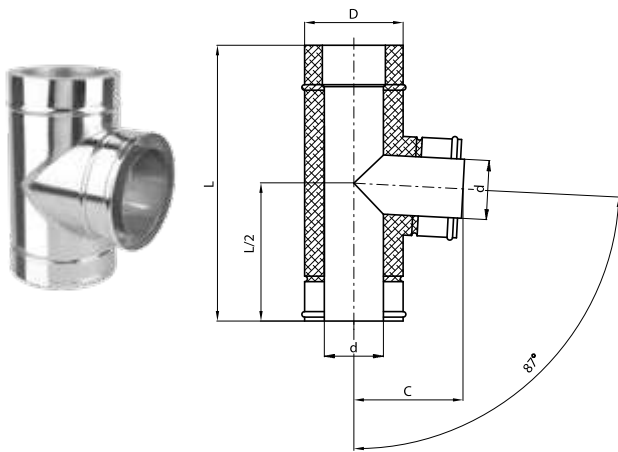
TEE SLIM EKO 87°

trade diam. d	130	150	160	180	200	225	250	300	350	400	450	500
trade diam. D	190	210	220	240	260	285	310	360	410	460	510	560
L	400			450		500		550	600	650	700	750
C	185	195	200	210	220	233	245	270	295	320	345	370

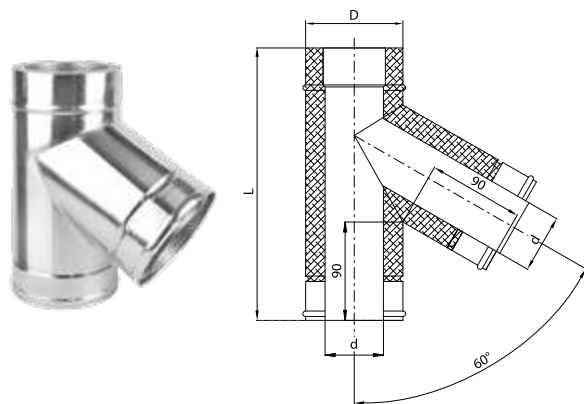
TEE SLIM EKO 60°

trade diam. d	130	150	160	180	200	225	250	300	350	400	450	500
trade diam. D	190	210	220	240	260	285	310	360	410	460	510	560
L	450			500		550		600	650	750	800	850

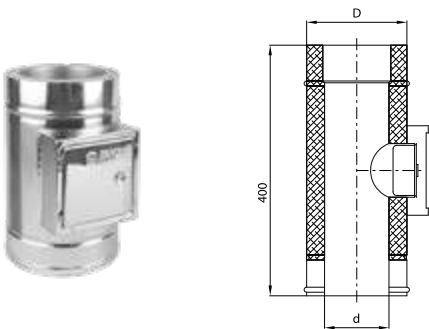
CLEANING HOLE SLIM EKO

trade diam. d	130	150	160	180	200	225	250	300	350	400	450	500
trade diam. D	190	210	220	240	260	285	310	360	410	460	510	560

BOTTOM SLIM EKO

trade diam. d	130	150	160	180	200	225	250	300	350	400	450	500
trade diam. D	190	210	220	240	260	285	310	360	410	460	510	560

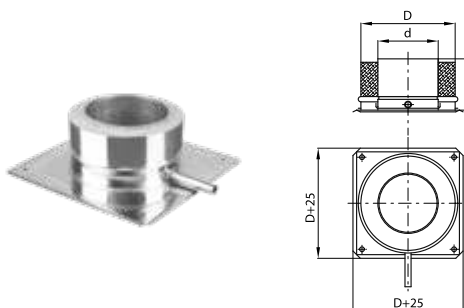

ANCHOR PLATE SLIM EKO WITH BOTTOM

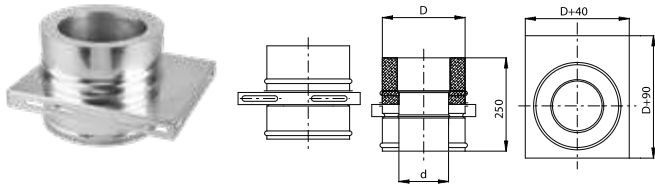
trade diam. d	130	150	160	180	200	225	250	300	350	400	450	500
trade diam. D	190	210	220	240	260	285	310	360	410	460	510	560

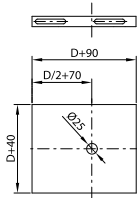

COUNTERBALANCE CONSOLE PLATE SLIM EKO

trade diam. d	130	150	160	180	200	225	250	300	350	400	450	500
trade diam. D	190	210	220	240	260	285	310	360	410	460	510	560



SUPPORT CONSOLE PLATE SLIM

trade diam. d	130	150	160	180	200	225	250	300	350	400	450	500
trade diam. D	190	210	220	240	260	285	310	360	410	460	510	560

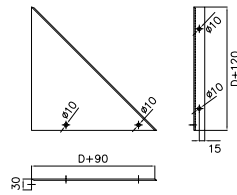

CONSOLE SUPPORT SLIM SET

trade diam. d	130	150	160	180	200	225	250	300	350	400	450	500
trade diam. D	190	210	220	240	260	285	310	360	410	460	510	560

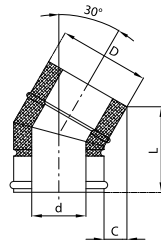

ELBOW SLIM EKO 30°

trade diam. d	130	150	160	180	200	225	250	300	350	400	450	500
trade diam. D	190	210	220	240	260	285	310	360	410	460	510	560
L	177											
C	45											

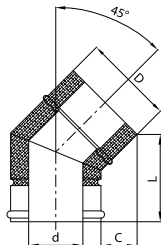

ELBOW SLIM EKO 45°

trade diam. d	130	150	160	180	200	225	250	300	350	400	450	500
trade diam. D	190	210	220	240	260	285	310	360	410	460	510	560
L	162											
C	62											

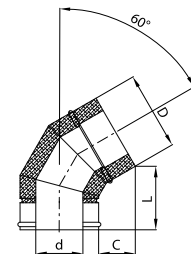

ELBOW SLIM EKO 60°

trade diam. d	130	150	160	180	200	225	250	300	350	400	450	500
trade diam. D	190	210	220	240	260	285	310	360	410	460	510	560
L	168											
C	95											

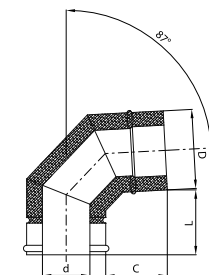

ELBOW SLIM EKO 87°

trade diam. d	130	150	160	180	200	225	250	300	350	400	450	500
trade diam. D	190	210	220	240	260	285	310	360	410	460	510	560
L	120											
C	115											

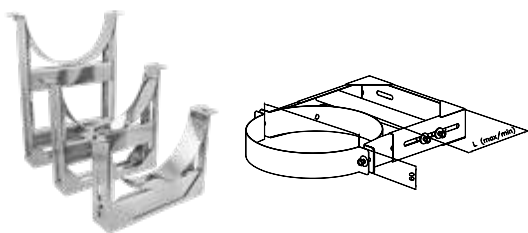

CLAMPING RING OBD SLIM 1, 2 OR 3

trade diam. d	250	300	350	400	450	500	RANGE OF ADJUSTMENT:		
trade diam. D	310	360	410	460	510	560	- OBD 1: 70-150 mm	- OBD 2: 150-300 mm	- OBD 3: 300-500 mm



CLIP OBL SLIM

trade diam. d	130	150	160	180	200	225	250	300
trade diam. D	190	210	220	240	260	285	310	360

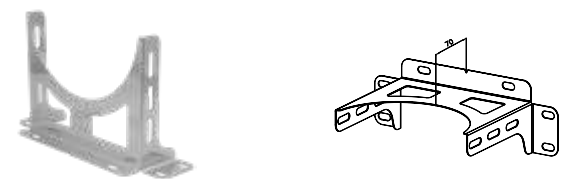

SUPPORT W1 OBL SLIM

trade diam. d	130	150	160	180	200	225	250	300
trade diam. D	190	210	220	240	260	285	310	360

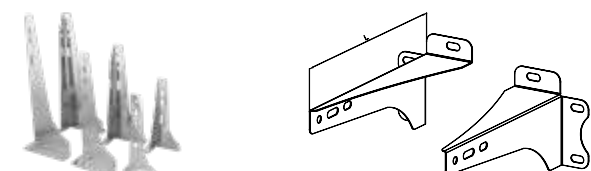

SUPPORT W2, W3, W4 OBL SLIM

	Range of adjustment	L
Support W2 OBL	150 - 250	240
Support W3 OBL	250 - 330	340
Support W4 OBL	350 - 430	440



MOUNTING CLAMP SLIM

trade diam. d	130	150	160	180	200	225	250	300	350	400	450	500
D3	190	210	220	240	260	285	310	360	410	460	510	570



ROSETTE SLIM

trade diam. d	130	150	160	180	200	225	250	300	350	400	450	500
trade diam. D	190	210	220	240	260	285	310	360	410	460	510	570



INSULATION ENDING SLIM

trade diam. d	130	150	160	180	200	225	250	300	350	400	450	500
trade diam. D	190	210	220	240	260	285	310	360	410	460	510	570

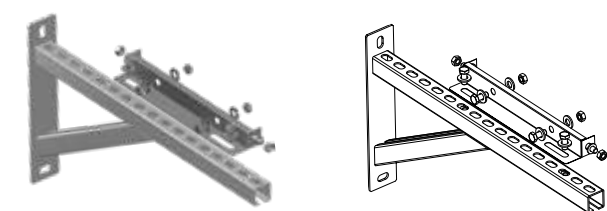

ADJUSTABLE CONSOLE SUPPORT SLIM SET

trade diam. d [mm]	130	150	160	180	200	225	250	300
trade diam. D [mm]	190	210	220	240	260	285	310	360
range of adjustment Lmin. ÷ Lmax. [mm]	70 ÷ 390	70 ÷ 370	70 ÷ 350	70 ÷ 340	70 ÷ 320	70 ÷ 285	70 ÷ 270	70 ÷ 210

ASSEMBLY MANUAL

VERSION I AND II

1. Forge openings in the wall according to the flue pipe run.
2. Set two rings in the opening for the flue pipe (on both sides of the wall) in such a way so that their common axis is level.
3. Mount a horizontal pipe into the embedded rings. Make sure that the flue operates in a slide manner.
4. Fix an connecting component with the boiler's flue on the pipe from item 3, from the side of the boiler station. When an adjustable component is used, adjust the dimension, lock and seal the pipes facing one another.
5. Mount a tee with a washout hole on the external side of the pipe from item 3 and fix them facing one another with a mounting clamp.
6. Find a vertical axis for the chimney in a defined distance from the external wall.
7. Mount the flue chimney's support console.
8. Mount counterbalance consoles in intended places as the chimney's installation progresses (see figures 1, 2).
9. Mount the chimney's vertical sections one by one. If an installation drawing is provided, the mounting sequence should follow the assigned numbering. Clamp particular elements with the use of mounting clamps. Mount the clamps according to the symbols placed on the inner side of the element. The method of mounting the chimney's particular elements is shown on the drawings: „Mounting stages of chimney elements”.
10. Fasten the mounted flue chimney to the external wall with available clamping rings every approx. 2 m (see figures 1, 2).
11. The last clamping ring needs to be located no more than 0.1 to 0.2 m from the wall top.
12. The maximum height of the chimney between the supports is 15m. If the chimney is higher, use counterbalance console.
13. Mount the last two pipe elements separately and put a mouthpiece over them. The connection may be additionally strengthened by jacket riveting.
14. Mount the chimney termination prepared in this manner on the installed flue chimney and fix with the last clamping ring. Pay attention to the maximum projection of the chimney above the last clamping ring (see figures 1, 2).

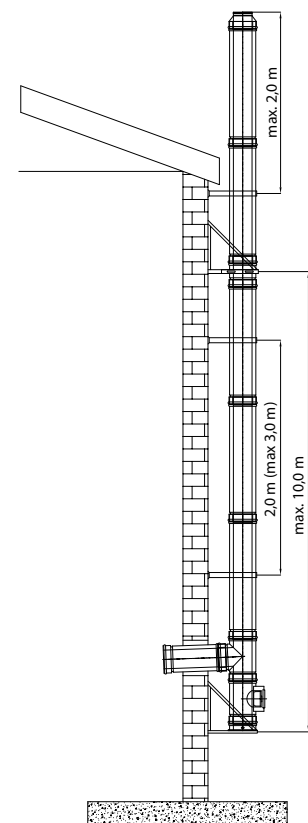
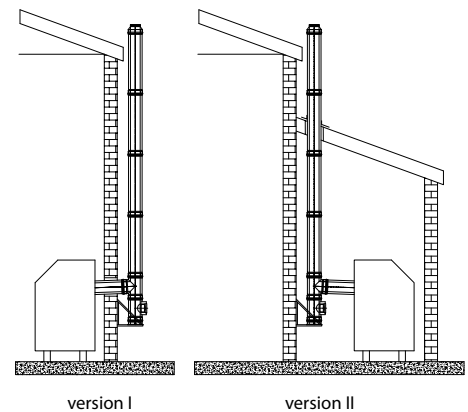

Fig. no. 1

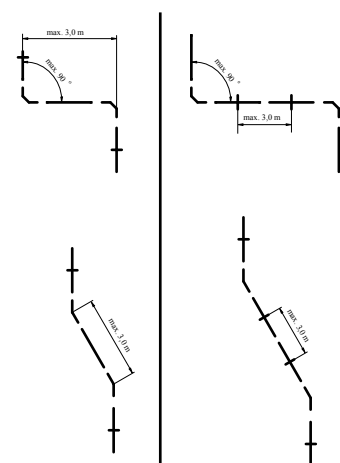

Fig. no. 2